



series
1552
2-Stage Servovalve
Rated flows up to 70 l/m



Features

- Standard & high response versions
- Maximum operating pressure 315 bar
- ISO 4401-05 mounting pattern
- External pilot supply
- Suitable for 3-way or 4-way applications
- Low hysteresis & zero point drift
- High spool drive forces
- Spool in bushing design
- Dry torque motor with mechanical feedback
- Long life Sapphire Technology



HYDRAUSTAR
ZA des Garennes
F41100 St FIRMIN des PRES

www.hydraustar.com

ST-1552-2016.1-Fr

Sapphire ball in slot design

- Incorporated into Star designs since 1988
- Many billions of cycles per service life
- Increased spool life due to spool rotation
- Ultra low coefficient of friction sapphire to steel
- Feedback mechanism unhindered by spool rotation
- Extended warranties available

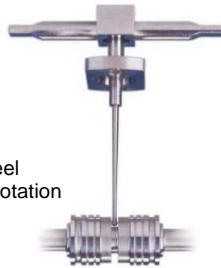

Safety

- Flame proof
- Intrinsic safety
- Class, Div & Zone coverage
- Mechanical failsafe
- Double & triple coil redundancy



Quality

- Independent audit process is our commitment on quality
- Focus on customer needs and expectations
- Delivery schedules on time
- Continual improvements on products and services
- Maintaining design and manufacturing integrity

Custom spool lap & bushing port geometries

- Zero overlap
- Overlap (closed center)
- Underlap (open center)
- Dual gain
- Asymmetric gain

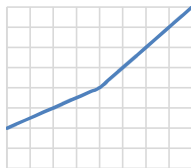
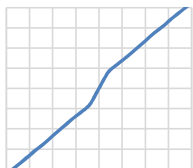
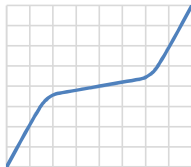
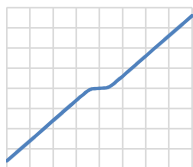
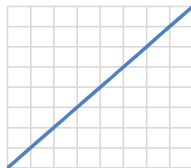

Sapphire flow

- Ensuring first stage stability
- Precisely matched flow properties
- Long life in extreme environments



Special projects

- Compact servo designs
- Special interfaces
- Modular components



Sealing materials

- Nitrile
- Fluorocarbon (Viton)
- Ethylene-Propylene
- Fluorosilicone



Special connectors

- MIL-C-5015
- MIL-DTL-38999
- Conduit style male/female
- Hermetic

Technical data

Hydraulic

Nominal flow ratings [$\pm 10\%$]	at 70 bar Δp	
	standard response	4, 10, 20, 40, 60, 70 l/m
	high response	4, 10, 20, 40 l/m
Operating pressure (max)	Ports	P, C1, C2, X R
Seal material	NBR, FPM	315 bar 315 bar
	EPDM	280 bar 210 bar
Fluid viscosity range (recommended)		10 to 100 mm ² /s (cSt)
Fluid type		Mineral oil to ISO 11158, DIN 51524 or equivalent MIL-H-5606 Skydrol Kerosene Water glycols others on request
Filter rating (recommended)	Pressure line	Beta 10 = 200 (10 μ m abs), non by-pass & indicator
	Off-line	Beta 2 = 1000 (2 μ m abs)
Fluid cleanliness	ISO 4406: 1999	
	minimum	16/ 14/ 11
	recommended	15/ 13/ 10

Operational parameters

Hysteresis		$\leq 3.0\%$ without dither	
Threshold		$\leq 0.5\%$ without dither	
Null shift	ΔT 40°C	$\leq 2.0\%$	
Internal leakage	140 bar supply (0.5% overlap)		
	2, 4, 10 l/m	≤ 1.2 l/m	
	20, 40, 60, 75 l/m	≤ 1.6 l/m	
Load pressure difference	1% input	$\geq 30\%$ of supply pressure can be as high as 100%	
Response time	0-100% rated spool stroke		
	standard response	2, 4, 10, 20, 40 l/m	8 ms
		60 l/m	13 ms
		70 l/m	15 ms
	high response	4, 10, 20 l/m	4.5 ms
		40 l/m	6 ms
Mounting pattern		ISO 4401-05 with special X port location	
Mounting position		Any, fixed or movable	
Weight	std unit	1.1 kg	
Design protection	EN 60529	IP 65	
Shipping protection		Sealed base plate	
Vibration		30 g all axis, 5 Hz to 2,000 Hz	
Shock		30 g all axis	
Seal material options		NBR, FPM, EPDM	
Temperature range		-30 to 135 °C	

Technical data

Electrical

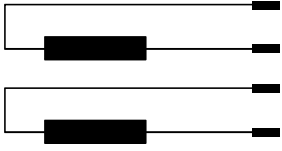
Rated input \pm (mA)	single (differential)	8	15	30	40	100	200
Other coil rates available	series	4	7,5	15	20	50	100
	parallel	8	15	30	40	100	200
Coil resistance (Ω)	per coil	1000	200	300	80	28	22
Power (W)	single	0,064	0,045	0,27	0,128	0,280	0,88
	series	0,032	0,023	0,135	0,064	0,140	0,440
	parallel	0,032	0,023	0,135	0,064	0,140	0,440
Connector pin out identification		A	B	C	D		
Polarity P»C2, C1»R	single	A +, B - or C +, D -					
	series	A +, D -, B & C linked					
	parallel	A & C linked +, B & D linked -					
Valve connector type	MIL-C-5015	MS3102E-14S-2P mates with MS3106F-14S-2S Consult factory for more options					
Standard connector orientation		P port					
	also available over	C1, C2 or R port; please advise when ordering					

Technical data

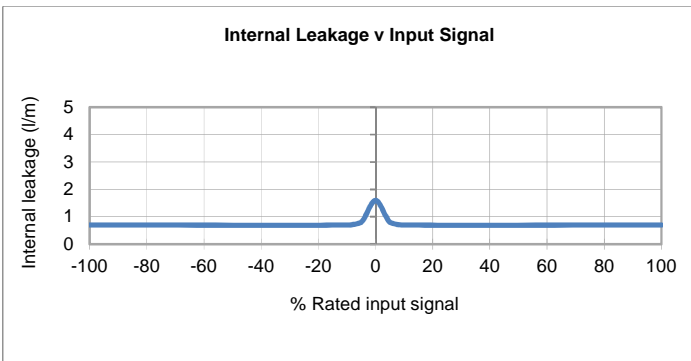
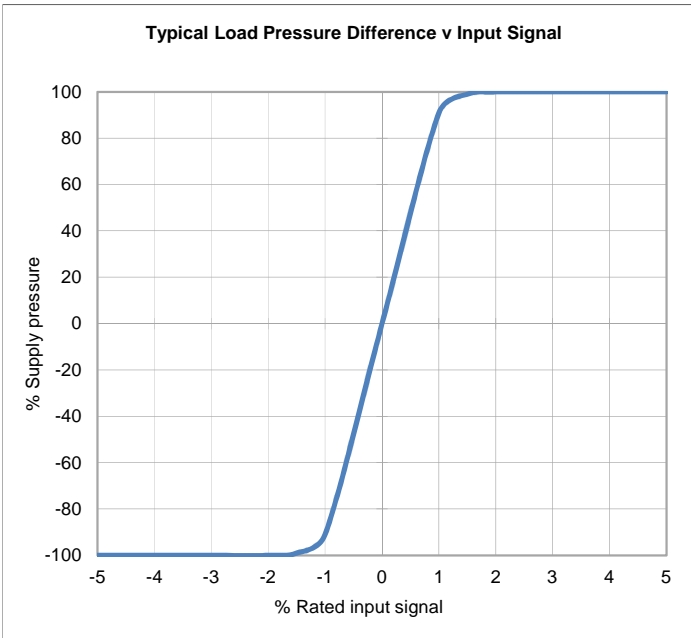
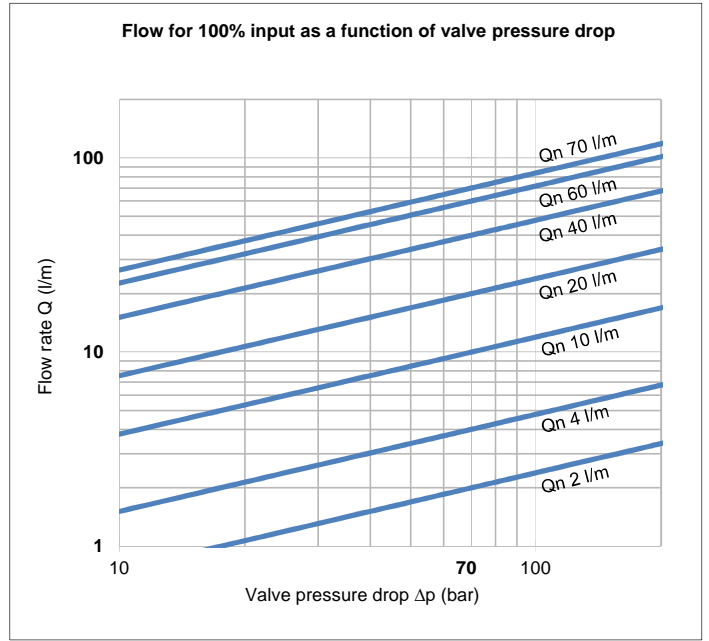
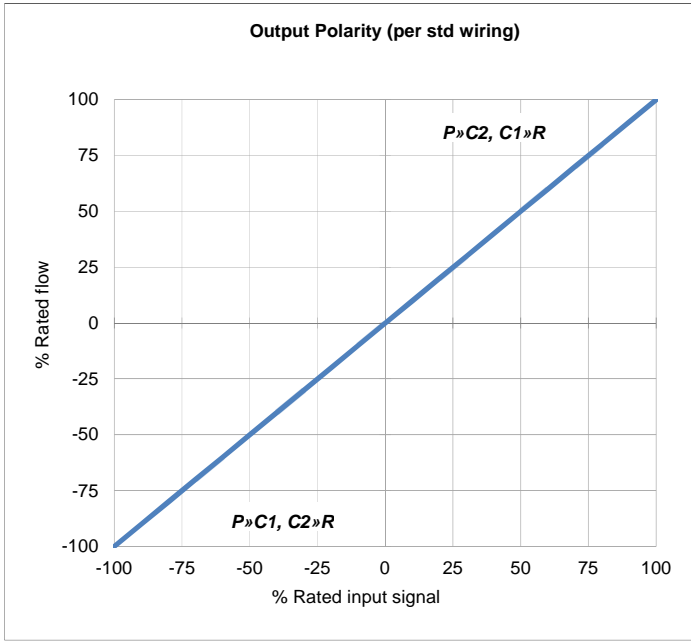

The flow tolerance for standard servovalves is $\pm 10\%$ of the rated flow at 100% rated input signal.

Rated Signal [In] is the specified input voltage or current of either polarity to produce rated flow. Rated input does not include null bias values.

Rated flow corresponds to the flow at rated input at 10 bar or 70 bar, with no load, therefore in 4-way valves there will be a pressure drop of 5 bar or 35 bar respectively across each land.

Load pressure difference versus input signal indicates typical differential pressure gain between ports C1 (A) and C2 (B) for standard lap spools. Negative and positive overlap change this characteristic significantly.

Internal leakage comprises of tare first stage and laminar leakage between spool and sleeve. With critical lap conditions in 4-way designs the leakage peaks through the null region.

Technical data

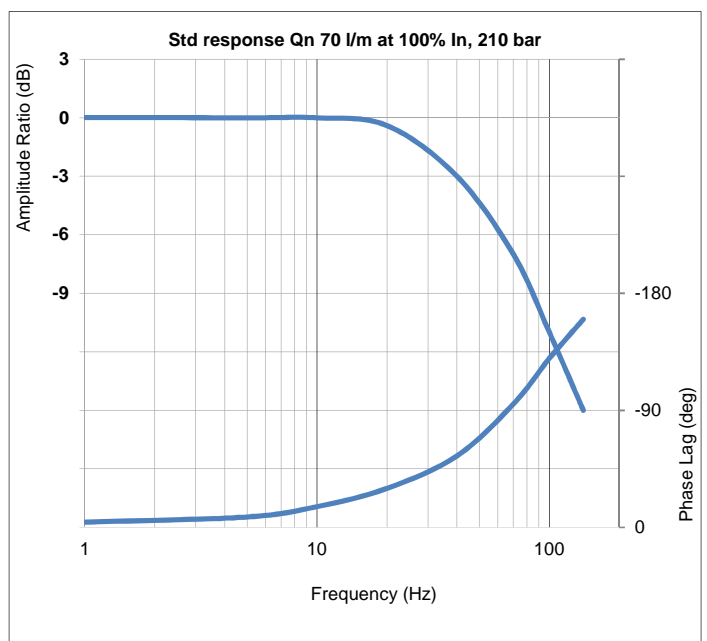
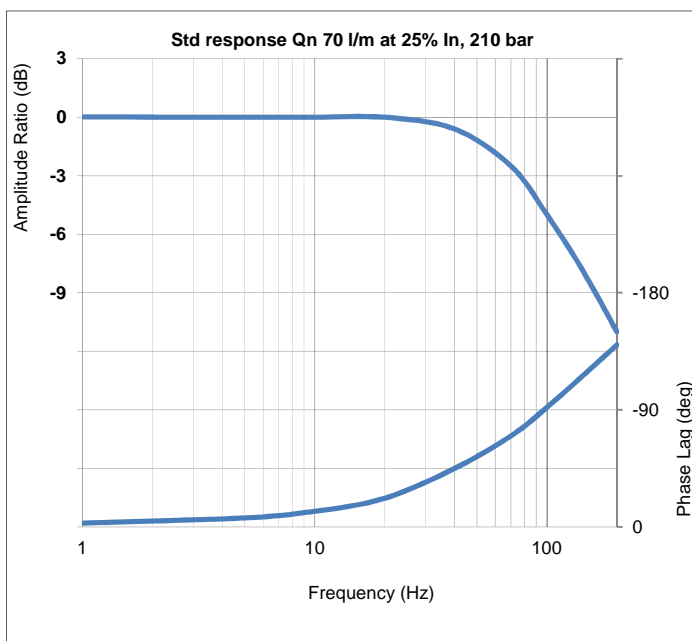
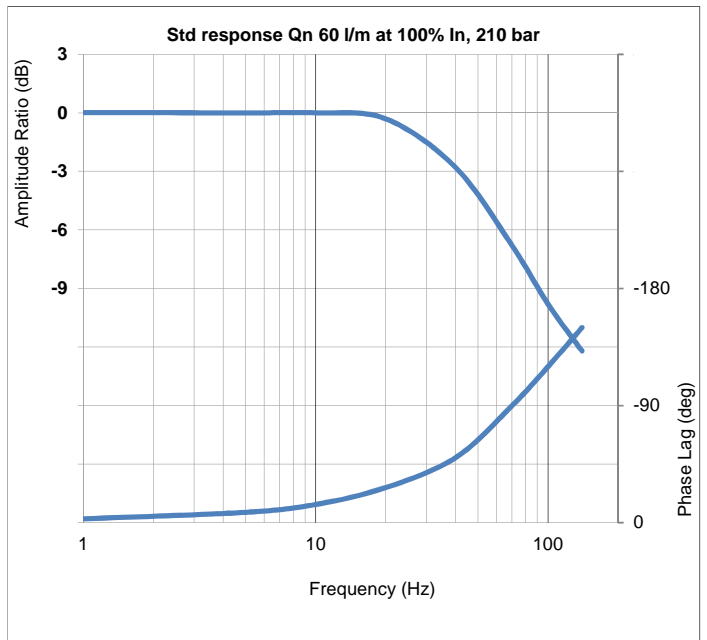
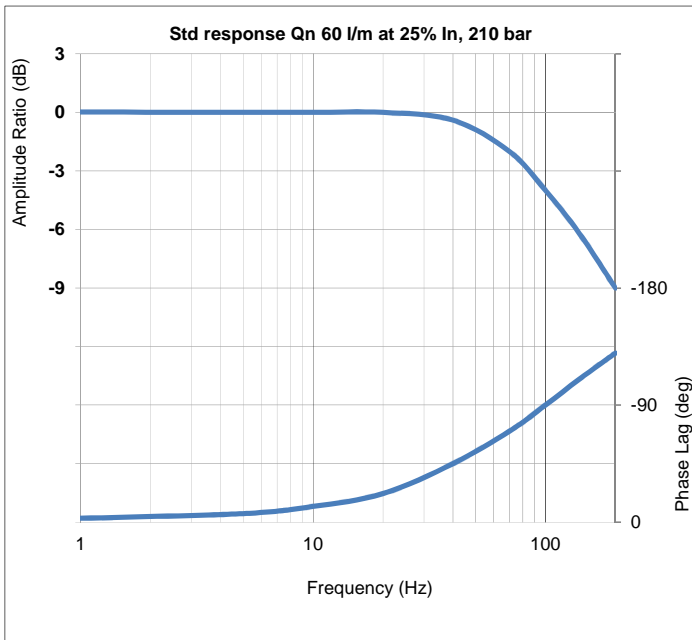
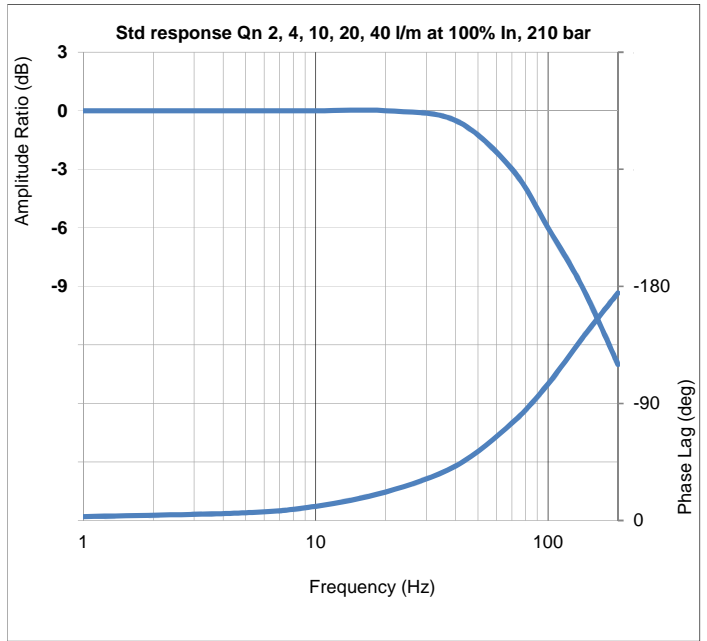
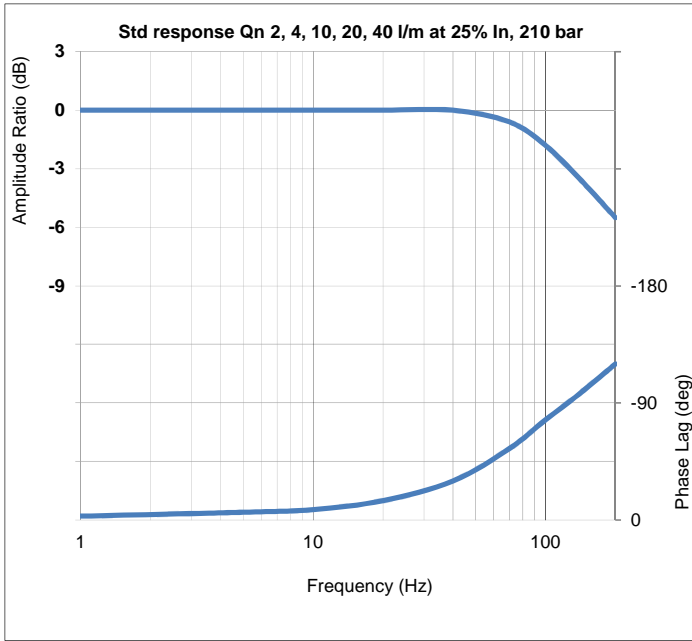

Technical data

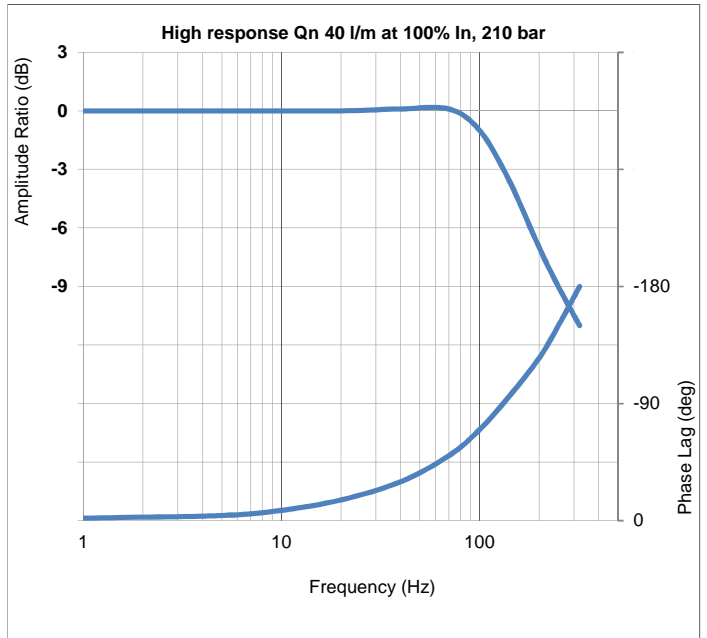
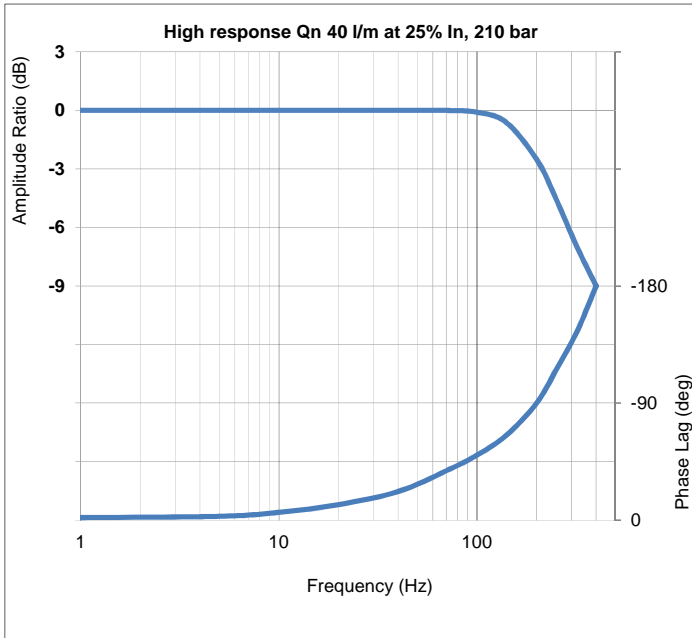
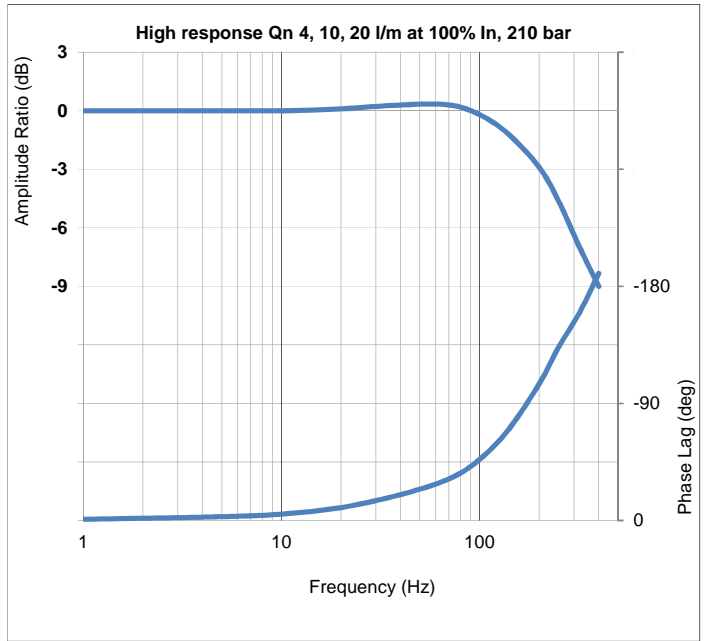
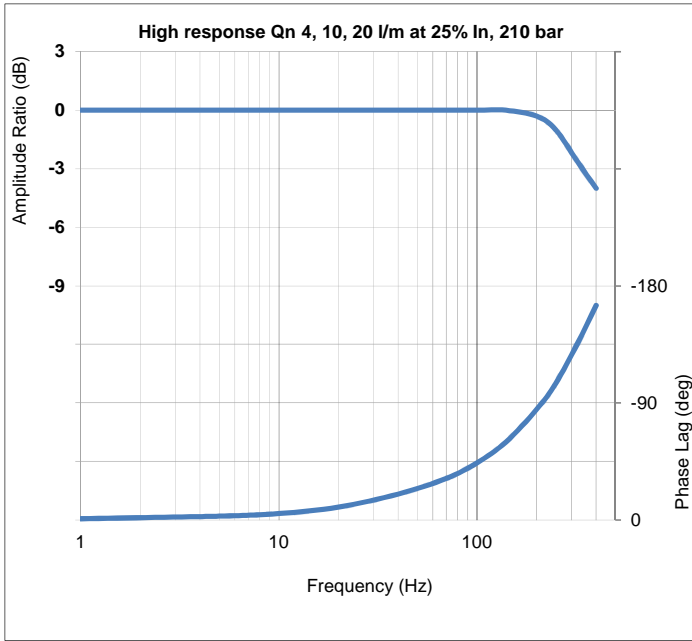

1552 series
 INSTALLATION DETAILS

Mounting screws	Skt head cap screws M6 x 45 - 10.9 ISO 4762
Null adjust (Mechanical)	- 2.5 hex skt & 10 A/F lock nut - slacken lock nut (ccw) half-turn with 10 A/F ring spanner - insert 2.5 hex key into socket and rotate to obtain required null / offset value - hold hexagon key in desired position then tighten lock nut to 2 Nm
Porting details	P, C1, C2, R, R2 ports $\varnothing 9.0$, \perp $\varnothing 15.85$ $\nabla 1.50$ X port $\varnothing 3.0$, \perp $\varnothing 11.85$ $\nabla 1.50$
Interface seals	Ports P, C1, C2, R, R2 - ID 12.0 x $\varnothing 2.0$ O-Ring Port X - ID 8.0 x $\varnothing 2.0$ O-Ring

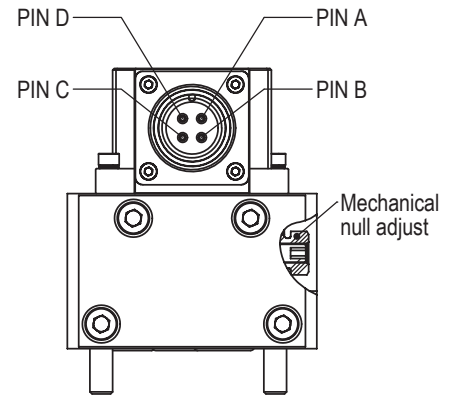
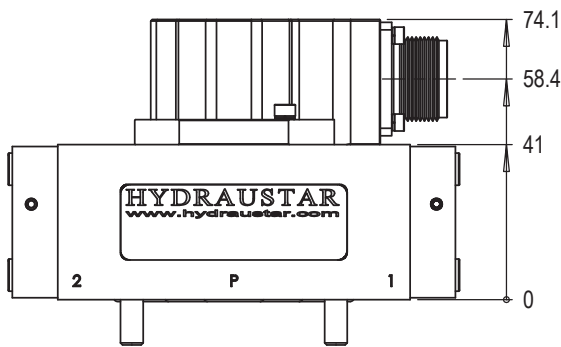
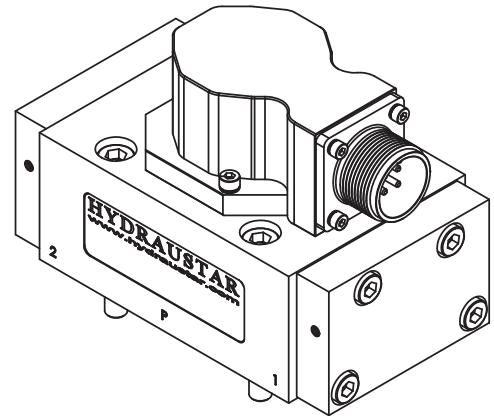
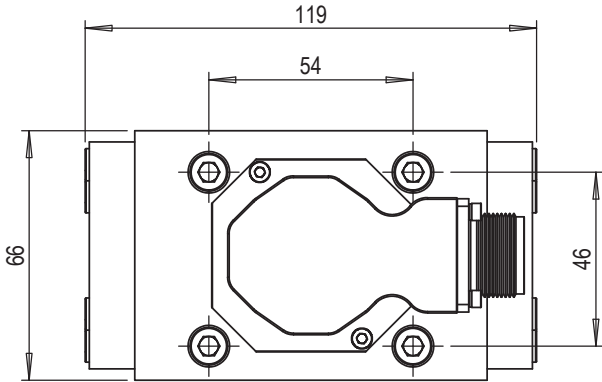

Mounting interface conforms to ISO 4401-05 (X port location non-standard)										
	P	C1	C2	R	R2	X	F1	F2	F3	F4
size	$\varnothing 9$	$\varnothing 9$	$\varnothing 9$	$\varnothing 9$	$\varnothing 9$	$\varnothing 3$	M6	M6	M6	M6
x	27	16.70	37.30	3.20	50.80	8.80	0	54	54	0
y	6.30	21.40	21.40	32.50	32.50	6.30	0	0	46	46

Surface flat within 0.01 / 100 : finish better than 0.8 μm

